

1- MLCOMBO50 LCD SCREEN USAGE

MLCOMBO50 has two lines 16 character LCD display and four buttons. Some information leds are available on the left and right of the LCD screen.

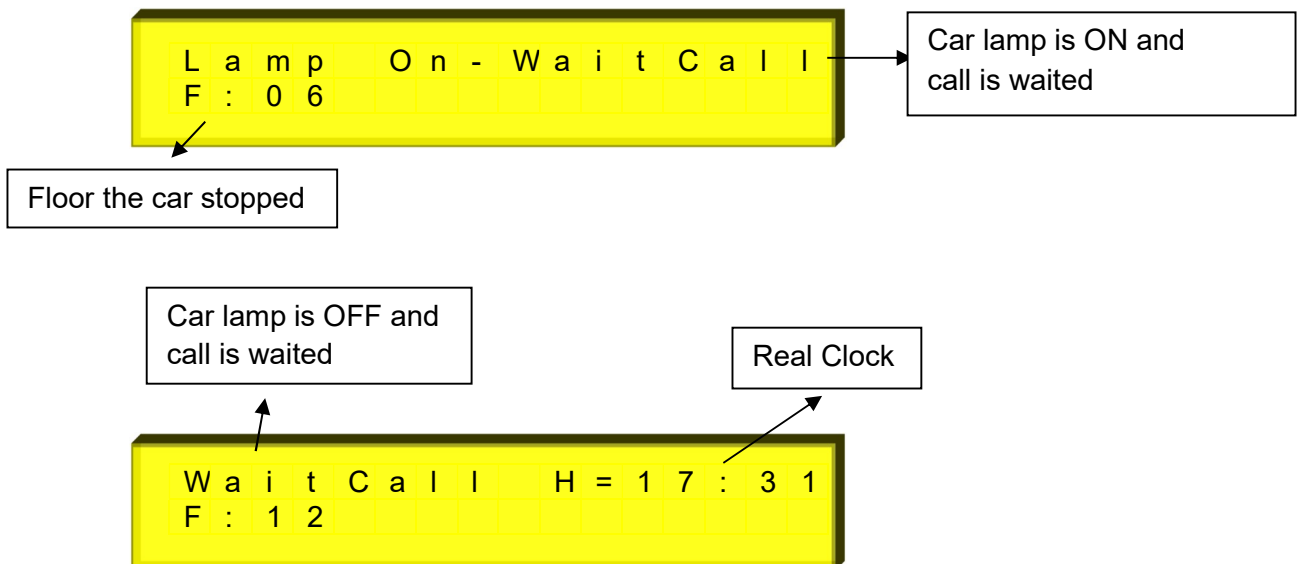

Lift position and fault datas are screened on LCD top line on MLCOMBO50. When the car is on stand by position, floor number is on LCD lower line.



When the car is moving, on the left side of LCD top line, there is target floor and on the right side of LCD top line, there are movement direction, speed and fault datas. On the lower line, the floor that the car position at the moment is screened.

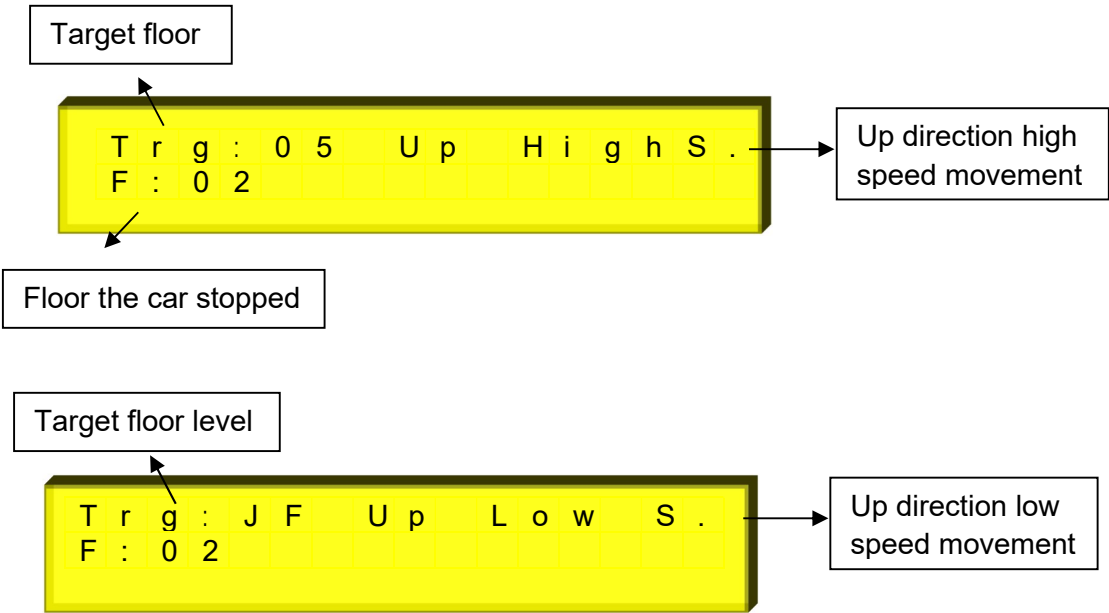

2- MLCOMBO50 BUTTON USAGE EXPLANATIONS

There are four buttons under LCD screen. Some functions are appointed to these buttons.

2.1- ENTER Button Usage

The inputs and outputs on MLCOMBO50 can be monitored with this button. Pressing this button for two seconds start to the program section. Another screen is display each time the button is pressed. The input and out screens shown below. If input or output is active , the sign “x” is shown in the bottom line of the display. If it is not active, the sign “x” is shown in the bottom line of the display.

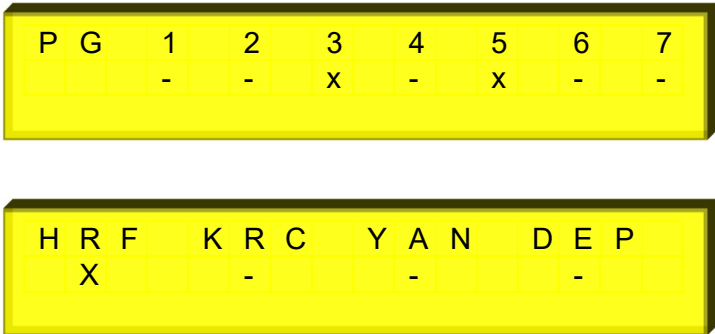

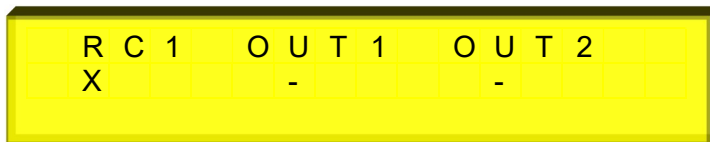
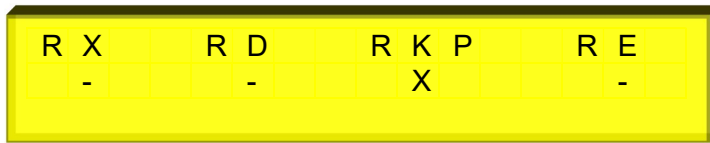
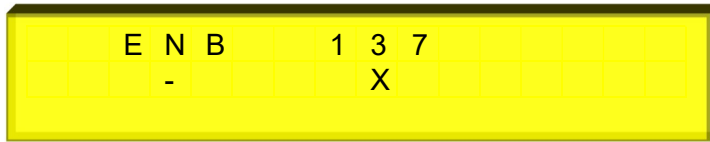
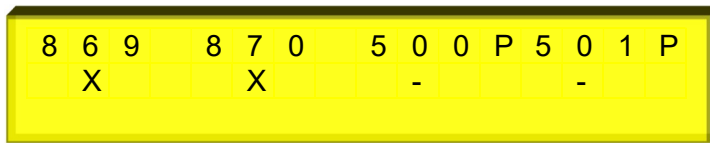

2.2- UP Button Usage

When pushed the up button every time, below screens are traced. Explanations are made.

Situation screens datas can be reached with up button and looked at between the screens.

Car Cards Communication Screens

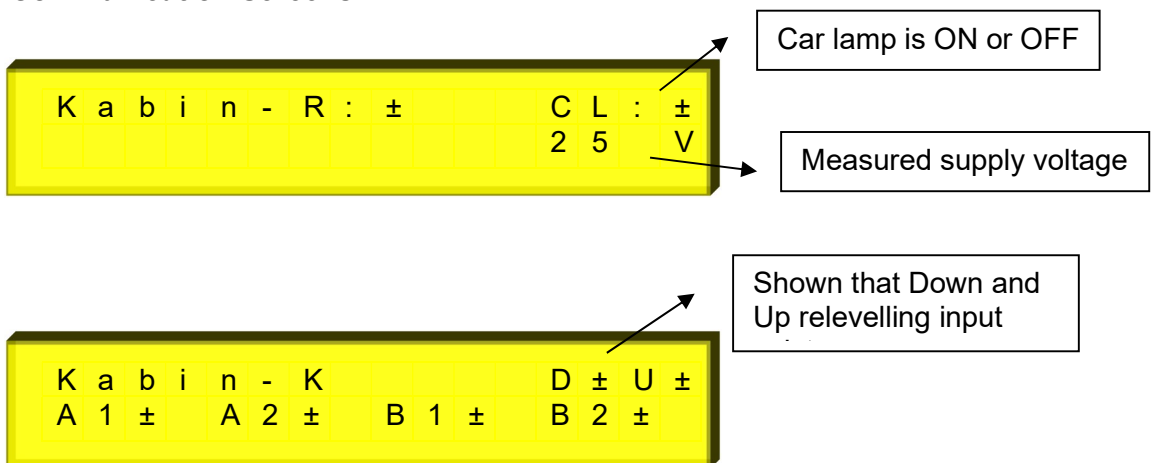

If there is communication with MLCOMBO 50 device, the sign will be "+" and if not, the sign will be "-".

Floor Cards Communication Screens



If there is communication with MLCOMBO 50 device, the sign will be “+” and if not, the sign will be “-”. if floor number is bigger than 16, the second screen will be traced.

Door Situation and Signals Screen

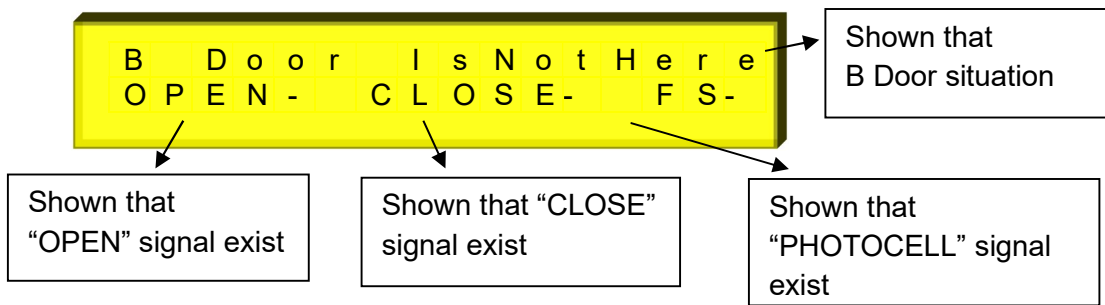
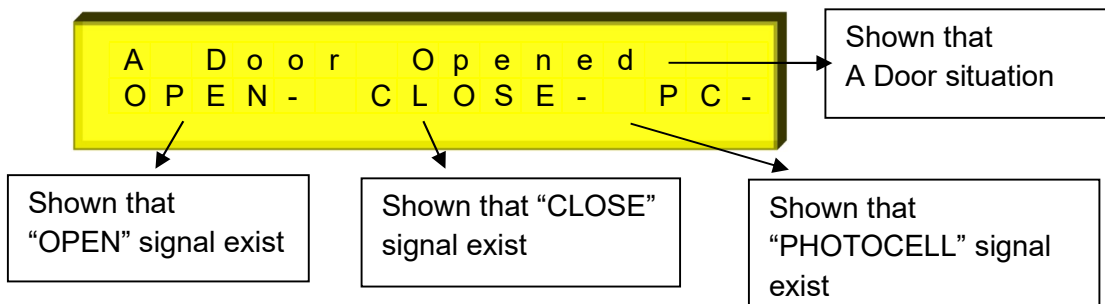

Car Calls Screen

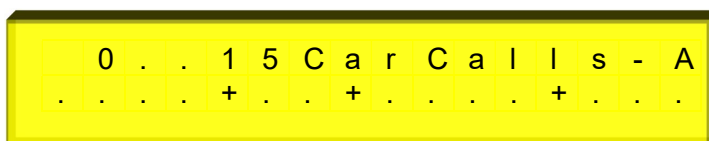

This screen is belong to floor card near door A, if floor number is bigger than 16, the second screen will be traced. The same situation is exist for the floor card near door B.

Floor Calls Screens

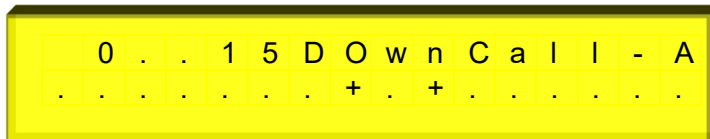

This screen is belong to floor card near door A, if floor number is bigger than 16, the second screen will be traced. The same situation is exist for the floor card near door B.

Maintenance Date Screen



Total Run Screen

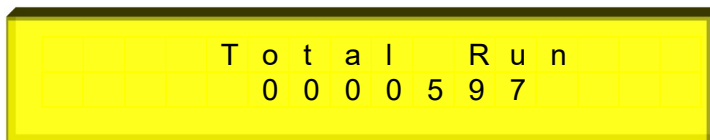

Run After Maintenance Screen

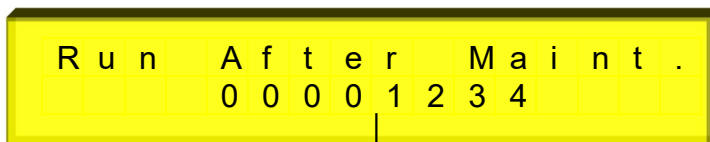

Shown that total run after maintenance

2.3- DOWN Button Usage

Driver and motor informations are monitored with this button. Another screen is display each time the button is pressed.

Motor Speed Screen

T	a	r	g	e	t	m	/	s	=	0	,	2	5
A	c	t	u	a	l	m	/	s	=	0	,	2	5

Motor RPM Screen

T	a	r	g	e	t	R	P	M	=	3	4	0
A	c	t	u	a	l	R	P	M	=	3	3	9

Motor Current And DC Bus Screen

I	m	=	3	,	2	1	A						
V	d	c	=	5	6	8	V						

Heatsink Temperature, Mechanical Break Relay And FAN Screen

T	h	s	=	3	5	c							
R	M	B	=	O	f	f		F	A	N	=	O	N

2.4- ESC Button Usage

If this buton is press ones, starts error tracing section. If this button pressed for two seconds the following three functions are started. These functions;

- 1- Inside the car calls,
- 2- Doing active or passive the floor doors,
- 3- Doing active or passive the floor calls.

When pushed down or up button every time, below screens are traced in order. If the function is requested to run, pressed ENTER. Floor doors and calls situations in that time (Active or Passive) are shown the bottom line.

2.4.1- Enter Car Call

Manual car call can be entered to the lift with down button.

Enter Call Screen

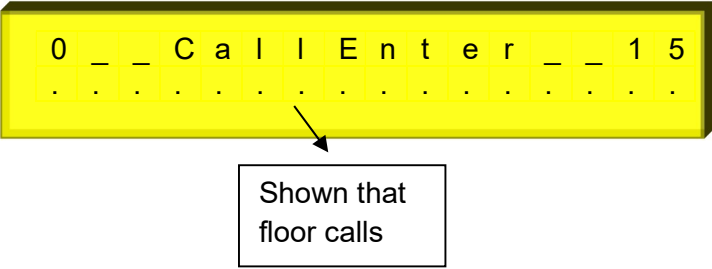

Dots on the screen indicate floor numbers in order. Floor that will be given call is selected with cursor and put "+" sign with "ENTER" on the floor number. More than one call, the other floors are selected the same.



To exit the function, it must be pressed to "ESC" button.

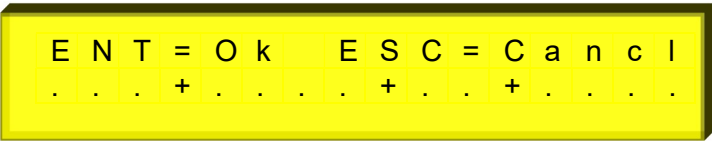

On the screen, registrations are canceled with "ESC" button or registrations are confirmed with "ENTER" button and exit from the function.

2.4.2- Floor Doors Active And Passive Function

When this functions is on the top screen, if pressed the ENTER button, arrow sign is traced the right bottom line of the screen. Then the floor doors situation, active or passive, will

be changed with UP and DOWN buttons on the bottom line of the screen. When pushed the ENTER button, arrow sign is deleted and the situation on the bottom line is selected.



2.4.3- Floor Calls Active And Passive Function

When this functions is on the top screen, if pressed the ENTER button, arrow sign is traced the right bottom line of the screen. When this functions is traced, if pressed the ENTER button, arrow sign is traced the right bottom line of the screen. Then the floor calls are changed active or passive on the bottom line of the screen. When pushed the ENTER button, arrow sign is deleted and the situation on the bottom line is selected.

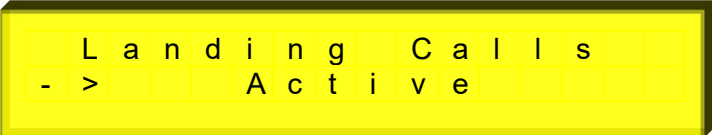

2.4.4- Registration Errors Tracing

If ESC button is pressed ones, starts error tracing section. Error tracing consists of two parts. The section called ML50S_Errors is lift system errors. The section called MLDRIVER_Error is motor drive errors.

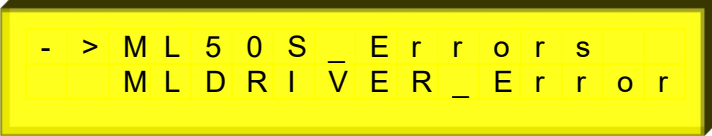

The arrow mark shown on the left side of the screen can be changed with the UP or DOWN button. When the ENTER button is pressed, starts the section that the arrow shows.

2.4.4.1- Registration ML50S_Errors Tracing

When the lift is working, some faults being in the system are registered with the direction, station, day and hour datas. It can be registered the last 16 faults. When the car is stopped, fault tracing function is started. Out of service lamp is ON.

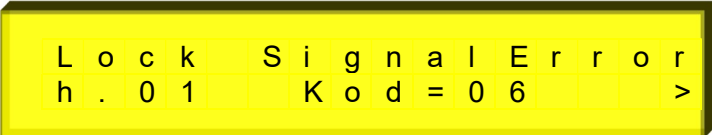

		and the lift is out of service till the door signal is detected.
5	<i>SafetyCir.Error</i>	After the lift movement is started, this fault is given when one of 120-130-140 inputs are cut. During 10 sec. fault is shown on the screen and then back to normal working.
6	<i>Lock SignalError</i>	When the lift will move, the situation that the lock signal is not detected. Door lock magnet is picked up during the time in menu B05 "LockWait Time" parameter. At the end of the time, if it is not detected 140 input, fault is given. The fault is registered with the direction data. At this situation the calls are deleted and lift is out of service during 10 sec.
7	<i>MaxHighSpeedTime</i>	While the lift is high speed movement, the situation that floor changing is not detected from pulse bi-stable in adjusted time at parameter. At this situation the calls are deleted and fault is registered with direction data. If "Only Warn" on menu B35 "AtSpd.Time End" parameter is selected, fault is given during 10 sec. and then back to normal working. If "System Blocked" is selected, system is blocked.
8	<i>MaxLowSpeedTime</i>	While the lift is low speed movement, the situation that jf signal is not detected in adjusted time at parameter. At this situation the calls are deleted and fault is registered with direction data. If "Only Warn" on menu B35 "AtSpd.Time End" parameter is selected, fault is given during 10 sec. and then back to normal working. If "System Blocked" is selected, system is blocked.
20	<i>Driver Fault</i>	Coming fault information from motor drive CPU situation. In this case, the error code and description received from the motor drive are shown on the screen.
21	<i>No 817 Signal</i>	Before coming the bottom floor, the situation of cutting 817 signal. The fault is registered with the direction data. At this situation the calls are deleted and lift is out of service during 10 sec.
22	<i>No 818 Signal</i>	Before coming the top floor, the situation of cutting 818 signal. The fault is registered with the direction data. At this situation the calls are deleted and lift is out of service during 10 sec.
24	<i>OSG/Brake Error</i>	This fault will be explained in the following sections.
25	<i>OSG Relay Error</i>	Detection of the relay on the independent OSG coil module not picked up. In this case, all calls are deleted. The lift is blocked.
26	<i>R PhaseError S PhaseError T PhaseError</i>	The situation that one the phases is not exist. If this situation is occurred while the lift is moving, the car is stopped by locating a call to the nearest floor in the same direction. If there is not a phase when the lift is stopped at the nearest floor or the

		car is stopped, the calls are deleted and the lift is out of service.
26	<i>R,S PhaseError R,T PhaseError S,T PhaseError R,S,T PhaseError</i>	The situation that two of three of the phases are not exist. If the car is moving, it is stopped; the calls are deleted and the lift is out of service.
27	<i>PhaseOrderError</i>	The situation that the phases orders connected to phase protection terminals (R, S, T) are wrong. At this situation the calls are deleted and the lift is out of service (Phase order is only controlled when the lift is stopped).
28	<i>M.Overheat(PTC)</i>	Fault of motor over heated. In this situation, if the lift is moving, the lift is stayed out of service position at the nearest floor.
29	<i>EARTHQUAKEInput</i>	
30	<i>FIRE Input</i>	
31	<i>Limit Error</i>	In shaft learning systems, this fault is occurred when 817 input is exist although the car is at the bottom floor or 818 input is exist although the car is at the top floor. When the fault occurs, all calls are deleted. The lift is stayed out of service position till the lift is inspection mode.
32	<i>DoorOpeningError</i>	To control the unintended opening of one or any of floor doors, it is connected to assignable inputs Door Control 1 and 2 from the control outputs of door situation control card (MLDC). This faults is occurred when unintended opening of one or any of floor doors. When the fault occurs, all calls are deleted. The lift is blocked.
33	<i>Driver Com.Error</i>	Communication interrupts with motor drive CPU situation. At this situation the lift is stopped, the calls are deleted and fault is registered with direction data.
34	<i>Car Door Error</i>	This fault will be explained in the following sections.
35	<i>DoorContactError</i>	This fault is screened when door open relay is picked up and 130 input is still exist, and the lift is blocked. At the same way, this fault is screened when door close relay is picked up and 130 input is not still exist, and the lift is blocked.
36	<i>Low VoltageError</i>	This fault is screened when the card supply voltage is dropped under 20V and the lift is blocked.
37	<i>Checksum Error</i>	Miss matched receive data from serial communication with checksum.
38	<i>Receive.DataErr.</i>	Failure to receive data from the motor drive CPU.
39	<i>TransmitDataErr.</i>	Failure to send data to the motor drive CPU.
50	<i>Shaft Learning Error</i>	At shaft learning system, if menu B31 "Floor Detection" parameter is selected "Encoder", this fault is screened. The lift is stayed out of service position.
51	<i>Encoder Reading Error</i>	At shaft learning system, while entering the floor door zone that the car will stopped, this fault is

		screened when the distance between ML1 and ML2 is not detected from the encoder. In this case, all calls are deleted. The lift is blocked.
52	Door M. Overheat	Fault of door motor over heated. In this situation, if the lift is moving, the lift is stayed out of service position at the nearest floor. All calls are deleted. The lift is stayed out of service position till the door motor temperature is back to normal.

2.4.4.2- Registration MLDRIVER_Errors Tracing

When the lift is working, some faults being in the driver module are registered with the day, hour, dc bus voltage, motor current and some datas. It can be registered the last 32 faults. When the car is stopped, fault tracing function is started. Out of service lamp is ON.

```

H i g h   D C   B u s   E r r .
e 0 1     C o d e = 3 0     >

```

When the function is started, the first fault shown at the screen is the last fault. If another fault is not exist “ No Fault “ message is screened. It is get to trace the faults by pressing UP and DOWN buttons. If you continue to press ENTER while any error is displayed, other information recorded in case of error is displayed on different screens respectively.

```

V = 8 7 1     I = 0 , 0 0
1 2 . 0 7 1 9     1 3 : 5 0

```

```

T h s =     2 5   I r A 3 F 3 F
E = 4 0 0 0 0 0 0 0 0

```

When ESC button is pressed or detected the car or control panel inspection key, fault tracing function is end. At the programming mode, if enter to MLDRIVER parameters “E.General Setting” section and select YES in (E11) parameter “Delete Errors” menu, registered faults are deleted.

Registered and descriptions are below.

ERROR CODE	ERROR SCREEN DISPLAY	EXPLANATION
2	<i>CommunicationError</i>	When there is a communication problem between the mainboard and the inverter, the motor is stopped and the motor energy is cut off. The motor will not start for 10 seconds, in this time the error is removed at the end and there are no other errors, the device works according to commands.
3	<i>Mechanic.BrakeErr</i>	Through connection to programmable inputs works. Mechanical brake checking failure. In the event of a mechanical brake failure, the device reduces the brake, the motor is de-energized for 10 sec. The motor is not started, at the end of this time the error is removed, if there are no other errors, the device operates according to the commands.
5	<i>IPM Error</i>	If there is an error from the IPM block the device is closed with giving the fault. The motor is not started during the 10 sec, at the end of this time fault is removed and if there is no fault, the device works according to the command.
6	<i>Low Speed Error</i>	Although motor current reaches maximum current, device error if speed is below 20% of reference speed and the motor is stopped. Motor for 10 sec is not started, after this time the error is removed and if no other errors, the device operates according to the commands.
7	<i>High Speed Error</i>	If the motor speed reference speed has passed by 20%, the device gives the fault then the motor is stopped. Motor for 10 sec the error is removed and if no other errors, the device operates according to the commands.
8	<i>Speed Limit Error</i>	If the motor speed exceeds 30% of the nominal speed of the motor, the device gives fault and the motor stops. Motor for 10 sec that the motor is not started. After this time the error is removed and if no other errors, the device operates according to the commands.
9	<i>ML_ENDAT Error</i>	When communication error between MLENDAT card and main processor, the device will give this error. Motor for 10 sec will not started, after this time the error is removed. If there is no fault other, the device works according to the commands.
10	<i>EncoderCom.Error</i>	If there is connection between MLENDAT card and Heidenheim encoder or the communication is in, the device will give this error. The motor will not started for 10 seconds. The fault will be removed, the device will be started.
11	<i>Encoder Error</i>	This error is active when the control mode "Off Loop" is selected. If the speed information cannot be read from the encoder, the device will give this error. The motor will not be started in 10 sec. At the end of this time and if there is no fault other, the device works according to the commands. In this case the encoder can be broken

		encoder feeding cables may not be connected or may be out of place, or the encoder may not be connected at all.
13	<i>Low MotorCurrent</i>	If the motor does not draw any current when the speed command is, if the motor current is too low, the device will give the fault and it will stop. The motor will not be started. After a while the fault will be removed and if no fault, the device will works according to the commands. In this case the motor connections and check the motor contactor.
14	<i>LockedRotorError</i>	Although the motor is energized when speed command is given if the motor does not move, the device cuts and gives errors. The motor will not started during the 10 sec, at the end of this time the fault is removed, if there is no fault other, the device is worked. In this situation, check whether there is a mechanical problem with the motor and whether the electromechanical brake is switched on.
15	<i>Motor PhaseError</i>	If at least one of the motor phases is not connected to the device interrupts the energy supplied to the motor and switches to fault. The motor will not be worked during 10 sec. After this duration the fault will be removed. If there is no fault other, the device is working according to the command. In this case, please check motor phase connections and motor contactor.
16	<i>MotorDirectionE.</i>	During the working with encoder, when giving the motor movement command, if motor is going to the reverse direction, the device gives the fault of direction, it stops the motor. The motor will not started during the 10 sec. At the end of this duration the fault will be removed. For this error, enter the "Motor Direction" parameter from the menu that should be done and change the setting of this parameter.
17	<i>Overload Error</i>	If the "Max. Current" value of the setted motor current passes during the Overload Load Perception Duration, the device will give Overload Error. The motor will be stopped. The motor will not started during the 10 sec. Then, the fault will be removed, the device will be worked according to the commands.
18	<i>OvercurrentError</i>	If motor current will pass the device max. Current capacity during the Overload Load Perception Duration, the device will be given the fault of extreme current. The device will be stopped. The motor will not be started during the 10 sec. Then the fault is removed and the motor works according to the commands.
19	<i>ContactorRelease</i>	When the device drives motor, the motor conductor is dropped, ENB signal is cut. The device is passed to the fault. The energy of giving to the motor will be cut. In order for the error to disappear, it is necessary to coming to the ENB signal and error waiting time (10 sec) must be completed.
20	<i>ContactorSetErr.</i>	Within 5 seconds after the speed signal coming, if there is no ENB signal, the fault will be given. The energy will be cut to the motor. For removing the fault, ENB signal will

		be come or it is necessary to be completed error waiting time (10 sec).
21	<i>Identifica.Error</i>	If the fault occurs during the motor identification the energy is cut to the motor. Until the error is removed, the motor will not started. When the identification command comes, the identification procedur will be started.
23	<i>Thermic Error</i>	When Thermal Protection Monitoring is active under Advanced Settings, this rescue fonction is working. The programming input will be connected to the motor thermic (bimetal thermic or PTC) or brake resistor (bimetal thermic or PTC), because of the thermic temperature increasing, when open circuit is occurred, if motor is working , it will be stopped and until the error disappears, it will be not worked.
24	<i>InconsistEncoder</i>	This error is active when the control mode "Off Loop" is selected. When the connection is making false or encoder at least one of the cables are be ripped, the device gives this fault. When the fault will be removed, the device will not worked again.
25	<i>System Error</i>	If there is a system error in the device software, the device gives the fault. The device will not operate again until the error disappears. In this case, please contact with Mikrolift.
26	<i>Direc.CommandErr</i>	Both if Up and Down direction signs come to the device, the motor is stopped and the error disappears. The motor can not be restarted.
27	<i>Overheat Error</i>	If the temperature of the coolant to which the IPM and the bridge diode are connected exceeds 90°C, an error is given and the motor will be stopped. The motor is not restarted before the coolant temperature falls below 70°C.
28	<i>SupplyVoltageErr</i>	This gives the fault if the voltage at the supply input of the device has been interrupted. The device will not work until the error disappears.
29	<i>Low DC. Bus Err.</i>	This gives the fault if the DC bus voltage level is below the permissible level (Vdc, min). The motor is not energized until the fault is cleared. Mains Mode: Vdc, min = 400V, UPS mode: Vdc, min = 200V, Battery Mode: Vdc, min = 40V
30	<i>High DC Bus Err.</i>	This gives the fault if the DC bus voltage level is above the permissible level (Vdc, max). The motor is not energized until the fault is cleared. Mains Mode: Vdc, max = 715 V, UPS mode: Vdc, max =420V
31	<i>Parameter Error</i>	The breakdown in the proccessor memory of setting values in the parameters entered in the menu or memory breakdown or at the end of the wrong registration, if there is wrong value, it gives this fault.

3- DOOR TYPES SELECTION IN PROGRAMMING

Door types on each floors can be selected A side and B side separately. Door types can be indicated as; CarDo. (only car door automatic), F.Auto (floor +car door automatic), NoDoor (there is no door).

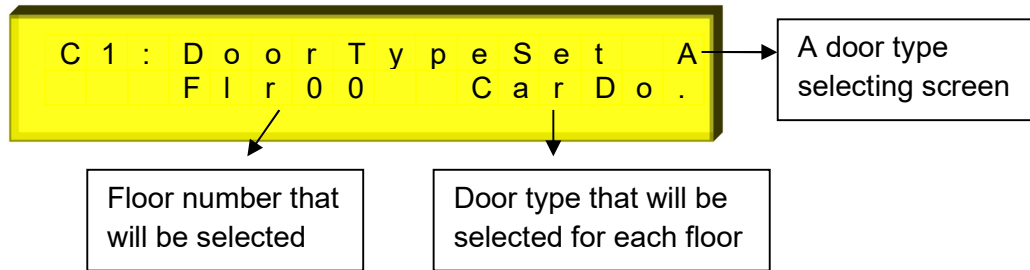

For selection, with lightening left arrow by pressing ENTER button, required floor is selected.

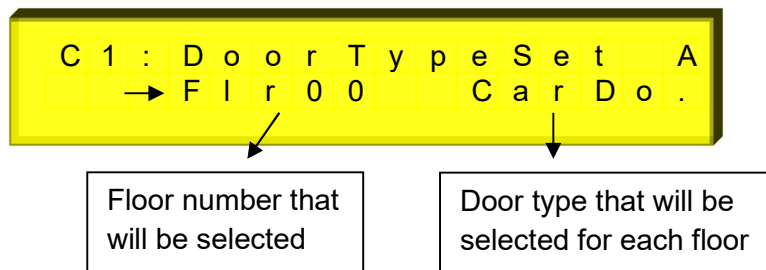

If floor door type is required to change, it is pressed ENTER button second time and lightened right arrow and door type is selected.

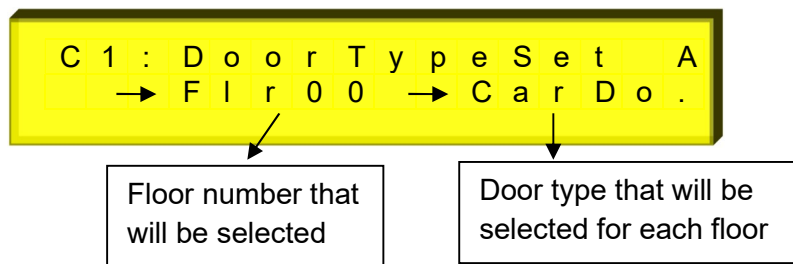

Also if all door types are the same type, "All" on the left side floor screen is selected, it is pressed ENTER button and door type is selected with second arrow on the right side and all floors door types are defined the same type.

4- FLOOR DISPLAY SELECTION IN PROGRAMMING

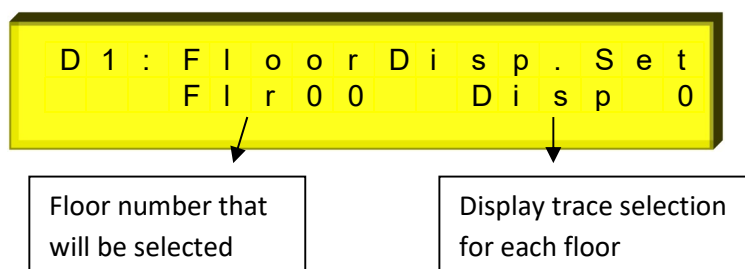

It is used for trace type selection that is required to be traced on floor for every floor. To change the parameter; first, by pressing ENTER button, floor is selected with arrow on left side. By pressing ENTER button again, display that will be traced is adjusted with arrow on right side.

If any floor display is adjusted a number value and the other floors displays are required to sort, it is pressed ENTER button during 2 seconds. "ENTER for Sorting" is started to flash on LCD bottom line. At this situation if it is confirmed by ENTER, all floor displays are sorted. ESC cancels the operation.

5- FLOOR LEVEL CORRECTIONS IN PROGRAMMING

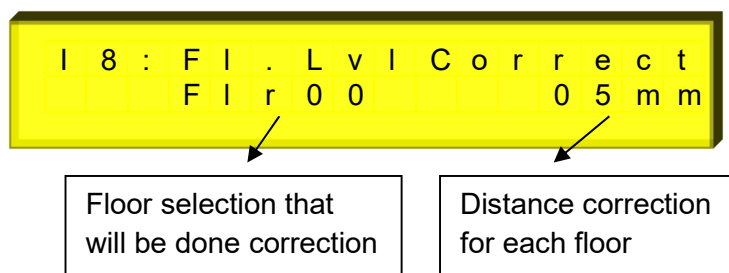

For each floor in shaft learning, at the situation of the car doesn't stop the floor level, it is used for accuracy correction. To enter the parameter, floor is selected with the arrow on left side by pressing ENTER button and by pressing again, distance correction is done as (-) or (+) value with arrow on the right side. Distances are indicated one by one or by using "All" option in the left side of parameter, the same correction for all floors can be entered.

6- WORKING OF DOOR BRIDGING SECTION and EXPLANATIONS OF THE FAULTS ABOUT THIS SECTION

6.1- Working of Door Bridging Section

Door bridging section is made up of three safety relays (RML1, RML2, RML3) and a mini relay (RE). Door bridging means to bridge the 120 and 140 inputs. It is explained that how to do this operation with below substances.

- When 24V is exist on ML1 and ML2 inputs (when the leds are lighted)
- RML3 relay is dropped and picked up for a short time.
- With RML3 relays dropped, RML1 and RML2 relays are dropped and stayed like this.
- It is controlled from the ST output that RML1 and RML2 relays are dropped.
- It is ready to bridging operation that RML1 and RML2 relays are dropped and RML3 relay is picked up.
- Then RE relay is dropped to door bridging.
- If the bridging is completed, it means 120 and 140 terminal pins are short circuit.
- RML1 and RML2 relays are stayed droppped if ML1 and ML2 inputs have 24V.

If any fault is occurs about the bridging section, RE relay is picked up.

6.2- Door Bridging Fault Descriptions

When door bridging operation is done, if the faults that descriptions are belowed are occurred, fault message is shown at lcd screen and registered to the memory. At this situation the lift is blocked by lightening out of service lamp. After the block operation, when the control panel power is cut and re-applied, "BridgeErrorExist" is traced on lcd and blockage of the card is continues. To cancel the blockage, must be entered to "J.GeneralSetings" and selected YES on "Del.BridgeErr" menu in (J05) parameter, and registered fault must be deleted. To look the registered fault, UP button must be used that is explained in button descriptions.

FAULT SCREEN DISPLAY	EXPLANATION	WHAT TO DO
<i>ML1-ML2 Shunted</i>	ML1 and ML2 inputs are short circuit.	Check ML1 and ML2 inputs that they are short circuit or not. Use different switches for ML1 and ML2 re-leveling zone mono-stable swithes.
<i>RML1-2NotPickUp</i>	There is no situation signal of RML1 or RML2 bridging safety.	If there are ML1 and ML2 signals, check RML3 relay is dropped at the start of bridging and then RML1, RML2 relays are dropped.
<i>RML1-2 Not Drop</i>	There is always situation signal of RML1 or RML2 bridging safety.	Check RML1 or RML2 relays are not pulled although there are no ML1 or ML2 signals.
<i>Not Bridged</i>	The signal is not detected from "140" input although bridging operations are done.	Check that RML1,RML2,RE relays are dropped and RML3 relay is picked up.
<i>140OnAfterBridge</i>	Although the end of bridging operation, signal is detected from "140" input.	Check RE relay is dropped.
<i>ML1 Shunt To 100 ML2 Shunt To 100 ML1=100,ML2=100</i>	Detecting ML1 and/or ML2 signal when the lift is at low speed movement because of detecting the target floor.	1-Check ML1 and/or ML2 input is not short circuit with 100. 2-Take the zone that the car passed to low speed to the front than the re-leveling zone.
<i>ML1 Missing ML2 Missing ML1-2 Missing</i>	Not detecting ML1 and/or ML2 signal when the car is stopped at call floor.	Check ML1 and/or ML2 inputs.

7- DOOR ZONE MAGNET LOCATION

ML1 ve ML2 mono-stable switches are shown how to be located below that will be used in the lift system do the re-levelling.

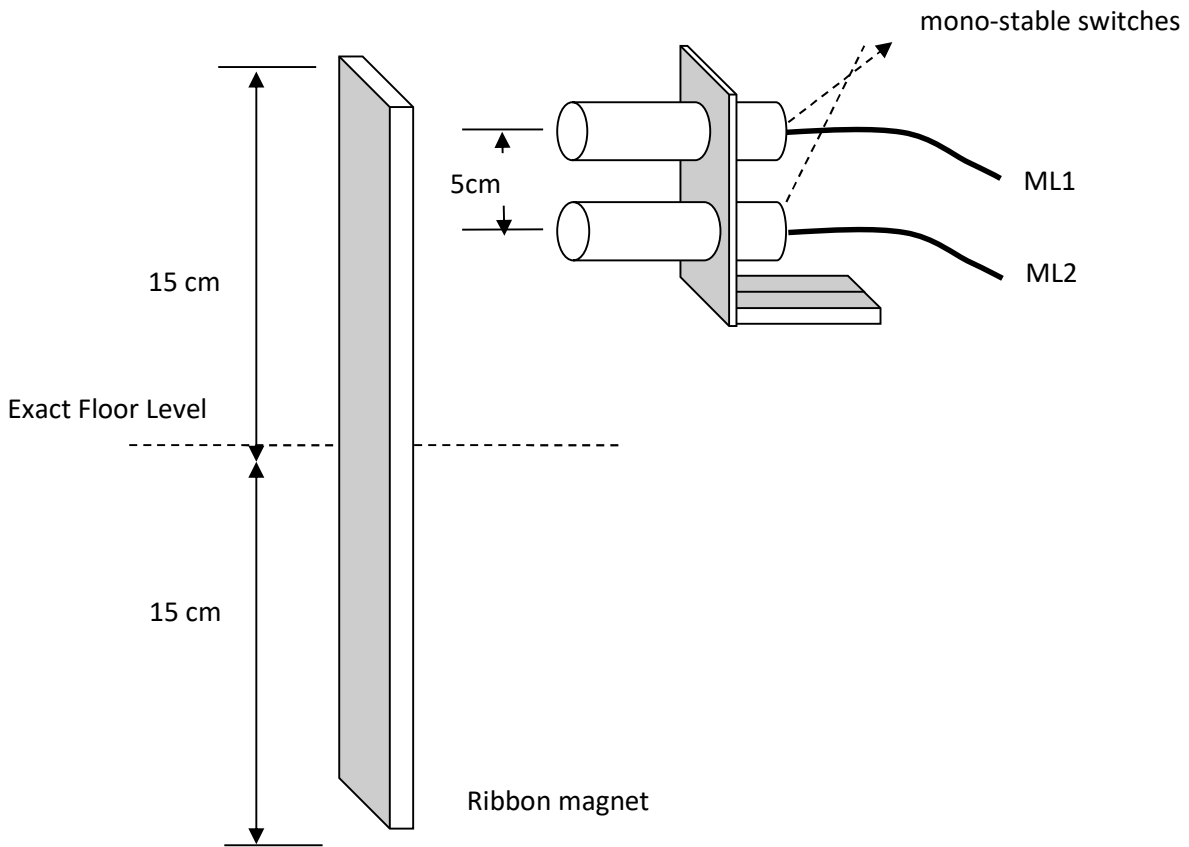

8- RE-LEVELLING MAGNET LOCATION

Mono-stable switches using for UP and DOWN re-levelling and ribbon magnets are shown how to be located below that will be used in the lift system do the re-levelling.

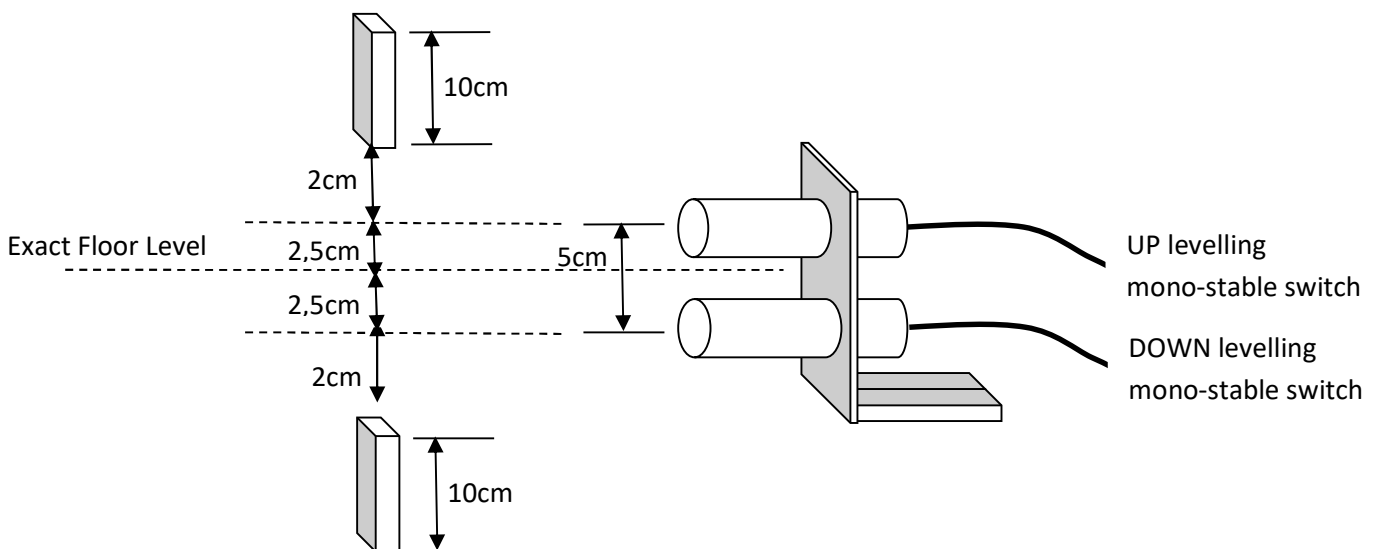

9- TRACING CAR DOOR EXTRA CONTACT AND DOOR SOCKETS

EN 81-20 standard requests an extra open contact that will work with car lock contact. This contact is NC type and one of the pins is connected to 100 (+24 VDC), the other pin is connected to an any assignable input. When the car is not moving and 120 input is exist, if 130, 140 and any of extra contact inputs are energized and two of them are not energized, then the fault occurs and "CarDoor Error" is shown on the top of the screen. A few time later after door closing relay dropped, if this input still has not energized, at the same time fault is screened and blocked the lift.

While the car is stopped and 120 input is exist; A few time later after door opening relay dropped, if 130 input is still exist, "Door Contact Error" is screened and blocked the lift. A few time later after door closing relay dropped, if 130 input is not still exist, at the same time fault is screened and blocked the lift.

When the car is moving at normal working, car extra contact input is not controlled. But in inspection mode, it is always controlled.

10- INSPECTION MODE

10.1- Taking the Lift to Inspection Mode

The lift can be taken to inspection mode by three ways; recall key, inspection key on top of the car and pit inspection key. Inspection key on top of the car and recall key are controlled by an input (869) that connected serial. If this input energy is cut, "Inspection" will be written on the left top of the screen. Pit inspection signal input is seperate (870). If this input energy is cut, "Pit Inspection" will be written on the left top of the screen.

10.2- Moving the Car to the Inspection Position

To moving the car in down or up direction, is pressed to direction button and (RUN) button at the same time. When the car is moving in up direction, "Up" is written on the right top of the screen and When the car is moving in down direction, "Down" is written on the right top of the screen.

When the car is not moving in inspection mode, all of the automatic door relays are not energized.

When the moving is started, closing relay is energized. If the safety circuit is completed, the car is moved.

When the car is moving, the car is stopped if the contacts are detected that are placed to pit and top of the well with 2m distance. To start again, hands off from the buttons first and re-pushed again. In this 2m zone, car is moved with the speed registered in inspection speed-2 parameter.

If the system has shaft learning system, without placing the contacts to top of the well and to pit, the distance between the top of the car and the top of the well and the distance between bottom of the car and the pit can be entered with "I14.TopOfWellDis."and "I15.Pit

Distance” parameters from “I.ShaftLearning” menu. So while the car moving, 2m distance of the top of the well and the 2m distance to the pit is calculated and no need to use contact.

Another control is according to “Ins.Mov.Type” parameter in Menu B-17 while moving in inspection mode; it is working to limit switches (817, 818) or to the exact floor. If “ToLimitSwitch” parameter is selected, car is moved till the limit switches will be OFF. If “ToExactFloor” parameter is selected the car is moved to top or bottom floor level.

10.3- Taking Out the Lift From Inspection Mode

If the lift is taken to inspection mode with top of the inspection key or recall key, to back to the normal mode, these keys are taken to the normal working position (869 input is energized again). After 869 input is energized, it is waited to cut the energy of 130 input (opening one of the floor doors) once for safety. If 130 input energy is cut, lift is taken to the normal working. This is important for the operator to open the door once while taking to the lift to normal working to exit from the well. So the lift movement is prevented with a call when the inspection key is passing unintended to the normal position.

If the lift is taken to the inspection mode with pit inspection key, to back to the normal working, the key is taken to the normal working position (870 input is energized again). After 870 input is energized, it is waited to cut the energy of 130 input (opening one of the floor doors) once for safety. If 130 input energy is cut, lift is not taken to the normal working immediately. Reset must be done (“Waiting Reset” is shown at the top of the screen). Reset can be done in two ways. First is to push the –ESC– button during 5 seconds. Second is any assignable input is energized and then cut. If the lift main power is cut without reset, reset operation will be registered and when the power on, reset will be waited again.

11- UNINTENDED CAR MOVEMENT (UCM) DETECTION

11.1- UCM Detection For The Electrical Lifts

Re-levelling can be done with door open or close. When the re-levelling is being done, it is detected that the car exit out of door zone with an input from “RML1” and “RML2” relays closed contacts. If it is detected that the car exit from this zone “UCMErrorDetected” is traced on lcd and stopped running. At this situation lift is blocked with lightening out of service lamp. After the block operation, when the control panel power is cut and re-applied, “UCM Error Exist” is traced on lcd and blockage of the card is continues. To cancel the blockage, must be entered to “J.GeneralSetings” and selected YES on “Del UCM Error” menu in (J06) parameter, and registered fault must be deleted.

11.2- OSG Fault Detection For the Lifts Has Geared Machine

OSG solenoid working is detected from “HRF” terminal via a closed contact on OSG. If it is detected that the solenoid dropped not correctly, “OSG/Brake Error” is traced on lcd. At this situation lift is blocked with lightening out of service lamp. After the block operation, when

the control panel power is cut and re-applied, "OSG/Brake Error" is traced on lcd and blockage of the card is continues. To cancel the blockage, must be entered to "J.GeneralSetings" and selected YES on "Del UCM Error" menu in (J06) parameter, and registered fault must be deleted.

11.3- Brake Fault Detection For The Lifts Has Gearless Machine

NC contacts of the two brakes that gearless machine had are connected serial to each other. It is detected that the info coming from this serial contact with "HRF" terminal. If it is detected that the brake dropped not correctly, "OSG/Brake Error" is traced on lcd. At this situation lift is blocked with lightening out of service lamp. After the block operation, when the control panel power is cut and re-applied, "UCM Error Exist" is traced on lcd and blockage of the card is continues. To cancel the blockage, must be entered to "J.GeneralSetings" and selected YES on "Del UCM Error" menu in (J06) parameter, and registered fault must be deleted.

11.4- Manual Test For Unintendent Car Movement

There are UP and DOWN direction test menus of MLCOMBO50 card for testing the detection of unintendent car movement (UCM) correctly.

Before doing UP direction test operation, car is taken to the floor level of the floor that is under the the topper floor. Than to start the test, must be entered to "J.GeneralSetings" and selected YES on "UCM Up Test" menu in (J07) parameter.

Before doing DOWN direction test operation, car is taken to the floor level of the floor that is on the bottom floor. Than to start the test, must be entered to "J.GeneralSetings" and selected YES on "UCM Down Test" menu in (J08) parameter.

These test operations simulates unintendent car movement (UCM) error that occures when the door is open normally as closed door. During the test, car is moved with low speed to the test direction. When the car is exit from the door zone, unintendent car movement (UCM) error occures and reset operations of the fault must be applied the same.

11.5- Cancelation OSG/Brake Control At Auto-Tuning

To do auto tuning as brake is closed in gearless systems, must be entered to "J.General Settings" and selected YES on "Auto Tuning" menu in (J09) parameter. So in INSPECTION mode, during 100 seconds after the first movement, OSG/Brake Control is not done.

11.6- Cancelation Over Speed Governor Solenoid Or Gearless Brake Control

If B32 parameter is selected PASSIVE, control of OSG solenoid contact or gearless brake contact that dropped or not is canceled after the lift stopped. But when the lift is moving, control is still going on. If B32 parameter is selected CANCEL A3, all controls are canceled.

IMPORTANT WARNING !



If B32 parameter is selected PASSIVE from ML50S_menu, system can damage more because of not checking of UCM faults that can be occurred on OSG selenoid or gearless brake. If parameter selected "Cancel A3" Mikrolift does not take any responsibility for these actions and Liftinstituut certificate is no longer valid.

12- BYPASS DEVICE

According to EN 81-20 standard, safety circuit bridging box must be done and connected to the control panel. Box contents and how to connect are shown in MLCOMBO50_11a and MLCOMBO50_11b schemes. Contacts that will be used in this box are suitable with EN 60947-1 standards. This box that the keys are placed must have cover and it is protected with lock to not used unauthorized persons.

Lift safety circuit working with bridging is like below using safety circuit bridging box:

1- At full automatic door systems, 120-130 and 130-140; at only car door automatic systems, 120-130, 130-135 and 135-140 can be bridged with safety circuit keys.

2- Bridging is done at only line. For example, when 120-130 is bridged, if 130-140 is requested to be bridged, bridging operation can't be done with the mechanical contact protection.

3- If any bridging key is taken to ON position, SCBO output will be OFF. This input is detected with any programmable input on MLCOMBO50 that is assigned as "Bridging Exist".

4- If it is detected that bridging is done, "Bridging Exist !" is traced on top of the screen.

5- In this situation, automatic door relays are made passive.

6- When bridging input is exist, lift can be run only inspection mode.

7- While lift is moving in inspection mode, Output that is assigned "Bridging Warn" is done active. So warning is given that the car is working while bridging is exist with a sound and light warning system that is connected to that output.

13- OVER LOAD FUNCTION

If the inside car weight is over than permitted, over load contact on the car is closed and 24V is applied to no.804 terminal. Microcontroller doesn't allow the car movement. In this situation "Over Load" is traced on the screen. Car lamp is ON and open relay is dropped to stay the door opened. Re-levelling is allowed if needed. When the over load contact is opened, movement is allowed again. While the car moving, over load control is not done.

14- FIRE FUNCTION

At the lifts in buildings that has fire floor, "B10.Fire Floor" parameter in B.SystemSettings is set to that floor value. If any fire contact in the floors are closed and "YAN" nicknamed terminal is energized, the car is moved automatically to the predetermined fire floor. While this input is exist, " FIRE Input Exist" is traced on the screen.

If the car is moving and fire floor is on the movement direction, all calls are deleted and the car is moved directly to the fire floor. If the car is moving to the opposite direction of fire floor, it stops the first floor, all calls are deleted and the car is moved to the fire floor without opening the doors. The car waits on the fire floor with open doors and doesn't answer the other calls. These are called "Phase-1". After this, fireman key input is waited. System remains blocked until the panel power is cut and turned on again.

15- FIREMAN MODE WORKING

After the fire input is detected and "Phase-1" section operations are applied, fireman key input is started to wait. To fireman mode working, below set and assigns are must be done:

- Fireman input is assigned to a programmable input.
- Door limit types of A and B doors are selected "With Limit".
- Fireman Call Delete input is assigned a programmable input (Not obligatory).

At the end of "Step-1", if the doors are selected "WithLimit" after the doors are wide opened, fireman input is started to control. If the fireman input is active, "Fire / Phase-2" is written on the screen and the car is given to fireman service.

If the fireman wants to close the car door, he must push the CLOSE button till the door closed. When the door is closing, if he takes his hands from the button, the door will open again. If he wants to open the car door like that, he must push the OPEN button till the door opened. When the door is opening, if he takes his hands from the button, the door will close again. The door is under control of fireman during Step-2.

Fireman gives only one inside call. Before the car is moved, with pushing Call Delete input, he can delete the call and give a new call.

When the car is gone to new floor in Phase-2, the door is not opened automatically.

If the firman input is canceled, it is exit from Phase-2 and back to normal working (If the fir input is still active, back to Step-1).

16- EARTHQUAKE FUNCTION

Building earthquake sensor that the lift is in is connected to "DEP" nicknamed terminal. When this input is energized, if the car is moving, it is stopped the first floor. "Earthquake Exist"

is written on the screen and it is waited with the doors are opened. When “DEP” terminal voltage is cut, the lift is back to normal working.

17- CONTACTOR CONTROL

24 VDC that is circulating serial from the contactors closed contacts that are providing the movement is connected to “KRC” terminal. Thus the card controls the contactors that are working correct or not when the car is stopped or moved. If the fault is occurred, “Contactor Fault” is written on the screen. Contactor control is done as below according to “B.SystemSettings” “B23.KRC Control” parameter content:

- 1) When the parameter is “Passive”, contactor control is not done.
- 2) When the parameter is “ Aktive “, control is done while the contactors are dropped.
- 3) When the parameter is “Full Active”, control is done while the contactors are both dropped and picked up.

When the fault is detected first time, the lift is waited out of service position during 10 sec. and then back to normal working. This fault is saved temporary. After that if the contactors work 5 times correctly, this temporary fault will be deleted. If the fault occurs before 5 times normal working, the fault is saved permanently and the lift will be blocked. To back to normal working, the main power must be cut and then given again.

18- FULL LOAD FUNCTION

Car full load contact can be connected to any assignable input. If the car weight is full capacity, full load contact is closed and 24VDC is applied to assignable input. In this situation, because of there are any place for the other passengers, while the car is moving, microcontroller doesn't stop the floors that are given as outside calls and the calls are stored.

19- VATMAN FUNCTION

Vatman key can be connected to any assignable input. When the car is stopped, vatman key input is controlled. If this input is active, all calls are deleted first and while this input is exist, only car calls are accepted. When the vatman key is OFF, lift is back to normal working.

20- PARKING FLOOR FUNCTION

While the lift is stand-by, when the time that is adjusted with parking floor time parameter is over, the lift is gone to the floor that is adjusted with parking floor parameter. If parking floor parameter is selected passive, this function is invalid.

21- SHAFT LEARNING

21.1- What Needs To Be Done For Shaft Learning

1) As shown at MLCOMBO50_17a and MLCOMBO50_17b schemes, 30cm ribbon magnets are must be used for all floor levels.

2) ML1 and ML2 that will be located across these magnets are must be electronic mono-stable switches.

3) ML1 electronic mono-stable switch must be certainly ABOVE.

4) Location of ML1 and ML2 electronic mono-stables must be certainly done 5 cm far away from the centers as shown in eight item.

5) Encoder connection must be like in MLCOMBO50_19 scheme. The shielded cables absolutely must be used in these connections.

21.2- Shaft Learning Usage Details

1) In pulse systems **817** and **818** limit switches were located a little bit top or a little bit bottom of magnets. In this system, limit magnets or limit switches are can be located to "passing to slow speed distance" place.

2) If there is really rope creep; if encoder value is not changed with the rope creep, **ASM** and **YSM** are must be connected..

3) In high speed systems that used middle speed output, when is moving to neighbour floor, passing to slow speed distance value (I03:Mid.Spd.Slow.) is accepted this value. In high speed systems that is not used middle speed, slowing distance from high speed (I02:HighSpd.Slow.) and slowing distance from middle speed (I03:Mid.Spd.Slow.) are must be selected the same.

21.3- Shaft Learning To Be Done

When the lift is stanby, it is entered to prgramming. In "I.Shaft Learning" menu, "I01:Learn Shaft" sub menü is selected **YES**. The card is first moved to 817 bottom switch position. Then, it is moved to bottom level of ML1 and ML2 and Shaft learning is started in up direction. In the left bottom of LCD passing floor number, in the right bottom of LCD encoder value is screened. After detected that 818 top switch is not exist, when it is reached to top of ML1 and ML2 level, Shaft Learning is completed.

In the Shaft Learning operation if safety device is cut or the lift is taken to inspection mode, Shaft Learning is canceled.

21.4- Floor Level Corrections From The Car

1) Is entered into "B.SystemSettings". "B33. Re-levelling" parameter is done ACTIVE.

2) Is entered "I.Shaft Learning". "I13.CorrectionMod" parameter is done ACTIVE.

3) Shaft learning is done.

4) Is exit from programming and is passed to normal mode. Then the car automatically will go to the bottom floor with position reset.

5) While inside the car, is gone to down direction with calling all floors in order. If level correction needed at that floor, is holded down to "OPEN" button. After 3 seconds, "d" letter is traced on digital screen and for down and up direction movement, the command is waited from "0" and "1" calls inside the car. While holding down to "OPEN" button, the car is moved to down direction if is holded down to "0" button; the car is moved to up direction if is holded down to "1" button. When the floor correction is done at that floor, "OPEN" button is dropped out. After 1 second is passed to normal working mode. If requested the correction again at that moment, the same process is done. When returned to normal working, is called another floor.

6) After gone to bottom floor, the same processes are done for all floors to up direction to top floor in order.

7) After floor level controls and floor corrections if needed are done with going to all floors for each direction, "I13.CorrectionMod" in "I.Shaft Learning" is selected PASSIVE. So exit "Correction Mode" and the temporary registered floor level corrections are saved permanent.

8) After four times working of the numbers of floors, if "I13.CorrectionMod" parameter is still ACTIVE, program will select this parameter as PASSIVE and the temporary registered floor level corrections will be saved permanent.

21.5- Another Method for Floor Level Corrections

After Shaft Learning is completed, exit from programming mode, by calling each floors, floor level correction distances are noted one by one in up and down directions. If the car is not reached to the floor level, distance value must be stored as (+); if the car passed the level, distance value must be stored as (-). These values are registered to "I08:Up Correct" and "I09:Down Correct" menu. If correction distances are bigger than -99mm or +99mm, ribbon magnets must be checked.

21.6- Position Reset

If B21.Position Reset parameter in System Settings is selected "Active"; In encoder Systems, when the power is ON first time, the car is sent to the lowest floor for position reset. If the car is in the zone that the bottom cutter is not exist or between the two floors that ML1-ML2 are not exist, first the car is moved to MI1-ML2 zone with INSPECTION speed. Then it is moved with normal speed in down direction.

If position reset parameter is selected "No", when the power is ON first time, if the car is at the door zone, position reset is not done. Before the main power OFF, registered floor is accepted as the main floor.

21.7- "I11.CalculateDistance" Parameter Usage

While "I11.CalculateDistance" parameter is PASSIVE, systems with shaft learning are working like M0 pulse systems as floor based. At floor based working, increasing and decreasing floors and passing from high speed to low speed was being in floors. Because of this, slowing distance is limited by floor height.

If "I11.CalculateDistance" parameter is selected ACTIVE; distance to target floor will be always calculated as milimetric. So the slowing distance from high speed or middle speed can

be selected without depending on floor heights. In systems that has very low floor height (min. 50cm) or in high speed systems (bigger than 1,6m/sec.) is started to slowing before one stop or several stops.

21.8- "I12.Slowing Dist.3" Parameter

This parameter is used in systems which has one floor or several floors that have low height less than normal height. In movement to next floor; if next target floor height is lower than the distance that is selected in "I03.Mid.Spd.Slow." parameter, slowing distance is being the distance that registered in "I12.SlowingDist.3" parameter.

21.9- Usage Shaft Learning in 2 Stops Systems

In 2 stops systems, before shaft learning, 30cm ribbon magnet is temporary placed to middle point of 0 and 1 stops. After the shaft learning operation, this ribbon magnet is placed out from its place. To be read the shaft as 3 stops by the program, "B03.Number Of Floor" parameter is again set as 2.

22- NUDGING FUNCTION

If the car door is left open for a long time by the passengers for no reason with pushing OPEN button or stopping obstructively in front of photocell (this time is the time that is adjusted in "C.Door Settings" section in "C.07 PhotocellTime" parameter), an assignable output is done active and close relay is dropped. This output is connected to "SLOW" input of automatic door control card. When the automatic door control card detected this input, closes the door slowly with a sound warning. To work this function properly, automatic door type must be selected "With Limit" and open and close limits of the automatic door must be connected to the control card.

8.23- SOUND OUTPUT FUNCTION

Sound output card (MLSERISES) can be plugged on MLKABIN-R50 top of car serial communication card optionally. So floor names, movement and door situation datas can be read with an another speaker except alarm speaker. Car warning gong sound can be given from this output or alarm speaker. Reading assignments for every floors about the sound output can be done in "K.Sound Settings" in programming.

24- ACCELERATION, DECELERATION AND DRIVER CONTROL PARAMETERS

In this section, it will be mentioned about how the device accelerates and decelerates according to the parameters in parameter programming "A.Travel Curve".

The description of Control parameter in the "C.Driver Setting" will be mentioned now.

24.1- Acceleration

The parameter changing of the device for acceleration is done from "A.Travel Curve" parameters ;

- A01.Initial Acc.(Acceleration), A02.Initial Speed, A03.Initial Time:

For the first movement of the car to tighten the rope and defeat the inertia will be speeded to motor initial speed with motor initial acceleration value. Motor is driven by

this speed during the preparation starting time. At the end of the period normal acceleration is initiated. This procedure is not applied if the preparation speed is selected zero.

- A04.Low Speed:

When the motor is driven at high speed, if the deceleration request receives from the lift controller cpu is be reduced to this speed level from the high speed. Motor is continued to driven by this speed when there are any of the UP and DOWN inputs and ENB inputs.

- A05.Re-Level.Spd. (Re-levelling Speed):

When the acceleration information received from the lift controller cpu, the motor will be accelerated to the selected speed value in this parameter content.

- A06.Insp.(Inspection)Low Speed:

When the acceleration information received from the lift controller cpu, the motor will be accelerated to the selected speed value in this parameter content.

- A07.Insp.(Inspection)High Spd(Speed):

When the acceleration information received from the lift controller cpu, the motor is accelerated to the selected speed value in this parameter content.

- A08.Middle Speed -1:

When the acceleration information received from the lift controller cpu, the motor is accelerated to the selected speed value in this parameter content.

- A09.Middle Speed -2:

When the acceleration information received from the lift controller cpu, the motor is accelerated to the selected speed value in this parameter content.

- A10.High Speed S6:

When the acceleration information received from the lift controller cpu, the motor is accelerated to the selected speed value in this parameter content.

- A11.Acceleration:

The acceleration of the car. As this value is increased to the required speed more quickly will be reached.

- A12.Acc.(Acceleration)Jerk Time:

With this parameter, the acceleration is started and the required speed is reached stepless acceleration time is selected.

- A19.Brake On Delay:

With this parameter, the mechanical brake release time is selected. This time the motor is hold at zero speed. At the end of the time the car is starting to be accelerated .

- A24.Ref.(Reference) Hold Time:
- If the request interrupt before reference speed is not reached, the request cancellation is accepted at the end of this time.

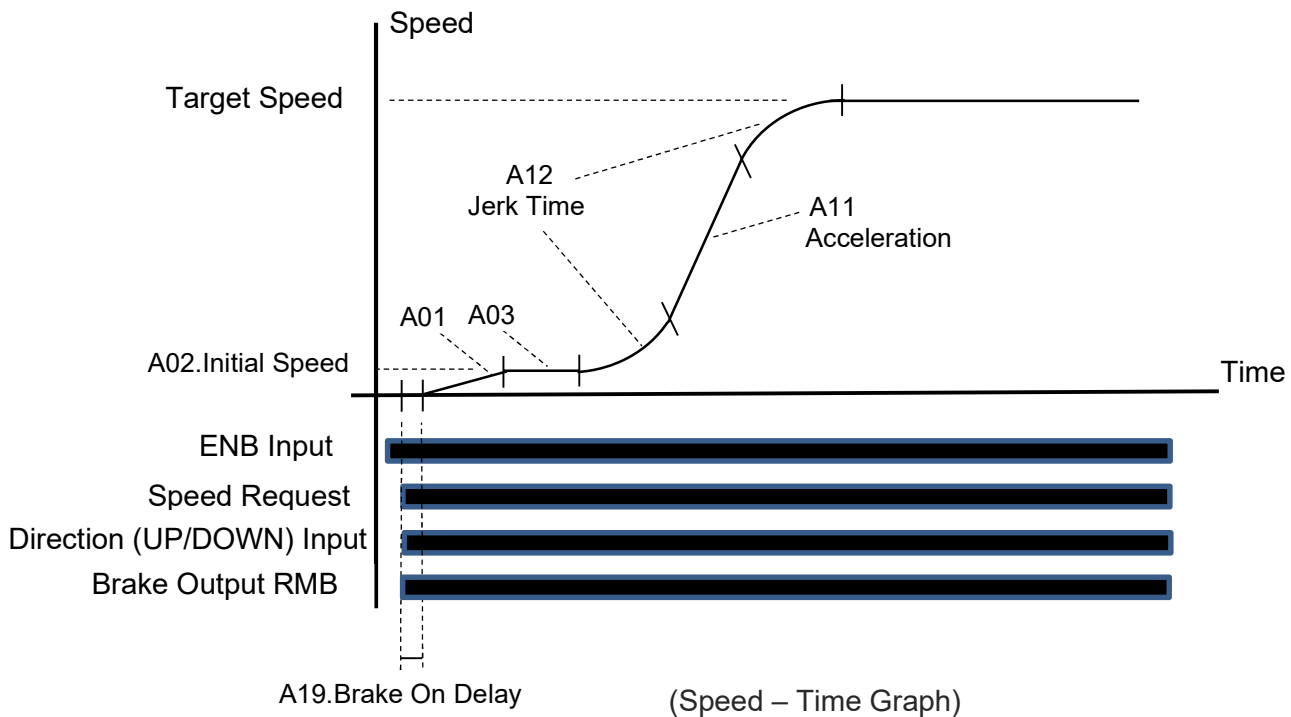

24.2- Slowing and Stopping With Parameter

The stopping type of motor can be changed " A16.Stopping Type " on the "A. Travel Curve ". If this parameter content is selected as "Parameter“, motor driven by a speed reference (A05...A10 parameter); if this speed reference is interrupted or another speed reference is request, the following deceleration acceleration and jerk is used. There are jerk and stopping parameters as follows;

- A13.Deceleration:
The deceleration of the cabin is acceleration. This value will be reduced more quickly to the required speed.
- A14.Dec.(Deceleration) Jerk Time:
When this parameter is started to decelerate and fall to the required speed stepless acceleration time is selected.
- A20.Brake Off Delay:
With this parameter, mechanical brake closing time is selected. During this time the motor is driven at zero speed.

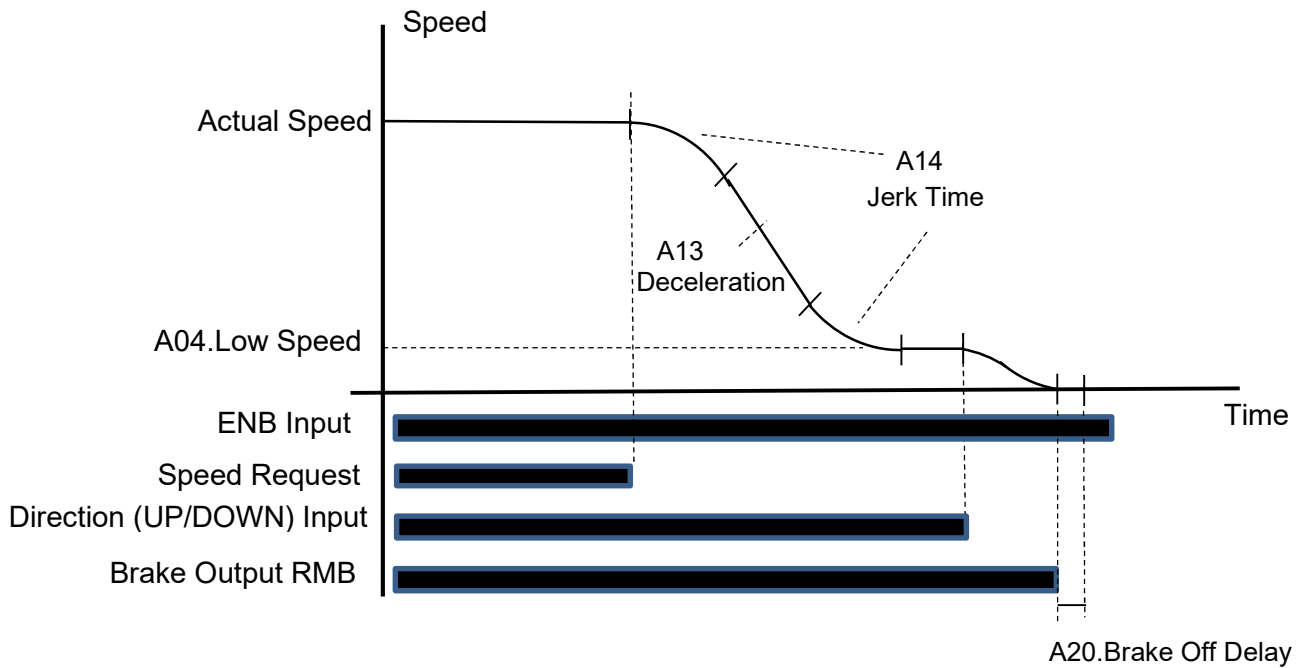

(Speed – Time Graph)

If the re-leveling reference request is interrupted while the motor is driven at A05 Re-leveling speed ; motor speed reduced to zero with deceleration and jerk. Brake closing time is waited.

24.3- Slowing and Stopping With Distance

If “Distance Mode1 (2-3)” is selected in the content "A16.Stopping Type" is selected parameter in “A.Travel Curve ” section, speed of the driven motor with speed input S6; if this input is interrupted, it is decelerated to the low speed at the selected deceleration distance. After stopping the direction signals, the speed is reduced to zero at the end of the stopping distance. The parameters are like these about this function:

- A15.Stop Jerk Cons.(Constant):
Stop type with this parameter ile with Distance Mode1 (2-3) selected jerk and stopping value selection is done.
- A17.Stopping Dist.(Distance):
With this parameter, starting distance of the direct to the floor is selected.
- A18.Slowing Dist.(Distance):
With this parameter, the transition distance from low speed to zero speed is selected.
- A20.Brake Off Delay: With this parameter, mechanical brake closing time is selected. During this time the motor is driven at zero speed.

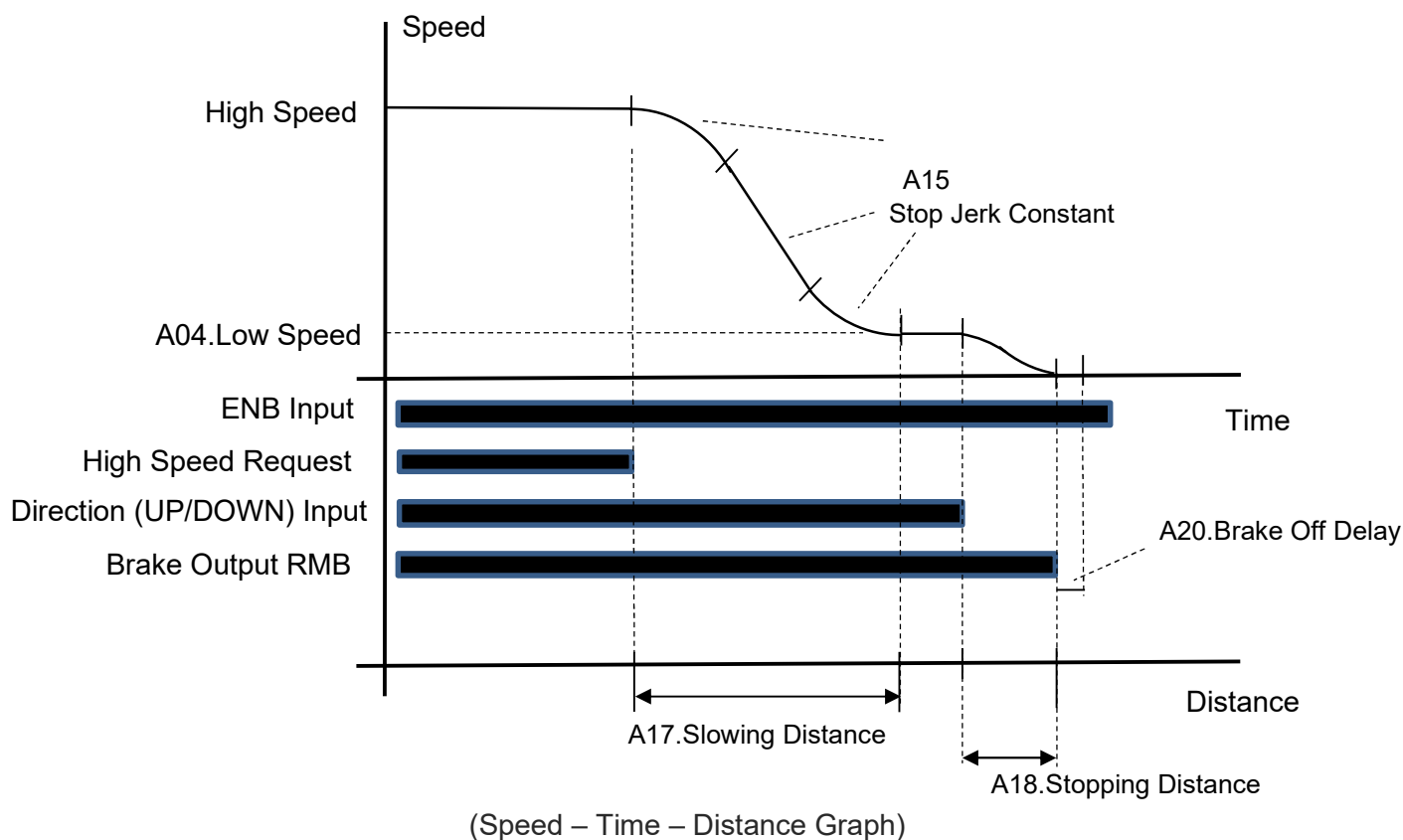

24.4- Control Parameters:

In this section, the control parameters used in the speed control algorithm of the device will be explained;

24.4.1. C13-Speed Control Parameter 1:

This parameter is the speed control hardness adjustment applied at zero speed.

24.4.2. C14-Speed Control Parameter 2:

The speed control applied when the motor reaches its nominal speed hardness adjustment.

At intermediate speeds the device will switch between these two parameters calculates the speed control parameter hardness according to the current speed. Control parameter 2 should be greater than or equal to control parameter 1. Increasing these parameters will increase the dominance of the device and will allow the application of the required speed curve to be more successful, but this increasing the parameters unnecessary, because of the noise and vibration from the motor increase, please be careful.

24.4.2. C13-Current Control Hardness:

It belongs to the device current control algorithm PI loop hardness adjustment. This as the value increases, the device will react more strongly to reach the reference current. As it is increased, the reference will reach the flow in less time and the margin of error is lower. However, increasing this value too much can cause vibrations and noise in the motor.

24.4.3. C01- Inertia Identify:

While the motor is not connected to any load including car ropes the inertia and friction coefficient values of the MLCOMBO50 device is a parameter that has been created to measure and save in memory automatically. When this parameter is selected "Yes", inertia measurement will be started.

24.4.4. C02- Inertia Value:

It means rotary motion proportional to the mass which is tightly connected to the rotor of the motor resisting size. In order for the motor to accelerate as the inertia grows amount of power to be applied should increase. It is an important parameter for speed control algorithm. It should not be changed unless necessary.

24.4.5. C03-Friction Value:

When the rotor of the motor is rotating, expresses the magnitude of the friction force to the reverse direction. It is an important parameter for speed control algorithm. It should not be changed unless necessary.

25- MOTOR IDENTIFICATION

Introducing the engine so that the engine can drive the engine efficiently and comfortably operation must be done as a motor identify. The steps for defining the motor are as follows respectively:

- The motor control board must be connected to the U-V-W outputs. The programming of the device is entered in the "Motor parameter" section. If the motor code is known, all parameters are provided automatically, by entering the motor code. If unknown, the motor type (Asynchronous or Synchronous) is selected firstly.
- Then, the values on the motor identification label respectively, programming must be entered in " B. Motor Parameter ". These values are;
 - B.03.Frequency
 - B.04.Number of Poles
 - B.05.Nominal Car Speed
 - B.06.Nominal Speed
 - B.07.Nominal Voltage
 - B.08.Nominal Current
 - B.09.CosQ
- "C. Driver Parameters" section after entering motor values C.12.Motor Identify Parameter doing "Active" and exit the programming.
- On the screen ;

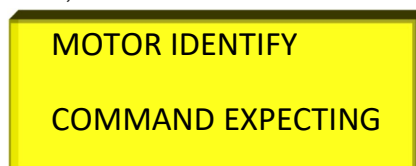

- After writing above, the device starts to wait for the command.
- In this case, the control panel is switched to "Maintaining" from the re-call terminal.
- It will be pressed and hold the UP or DOWN button. On The screen;

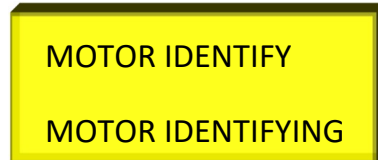

then you get the writing above.

- On the screen;

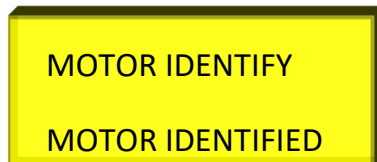

Continue to press the button until this post is on the screen the button is released and the motor identification is completed.

Note: If the device is not identified with a motor, " IDENTIFY THE MOTOR, PLEASE" is occurred the bottom of the line screen. In this case the device speed reference inputs of command only S1-S2-S3. The S4-S5-S6 speed inputs are active after the motor identification.

B.12.No Load Current Limit Parameter :

One of the most important parameters in asynchronous motor identification "No-load Current Limit" is. Because the asynchronous motor's no-load current is calculated during the motor identification process. The effect of this current value on the motor is as follows:

- If no-load current amount more than necessary, the motor has the amount of torque to lift the loading, however it may not reach full speed.
- If the amount of no-load current is less than the required amount of torque, the torque of motor' s applied is reduced than the motor may start to vibrate. Can draw excessive current from the grid, the device may enter the overload protection or never lift the load.

For motors up to 7.5kW, No-Load Current Limit parameter generally 40% of this parameter is sufficient, but above 50% level may be required.

Important note ! If you change this parameter after the motor identification, the motor you must repeat the process.